

STANDARD CHARACTERISTIC

- CONSTRUCTED IN ACCORDANCE WITH THE ASME CODE, SEC VIII 2010 11a, DIV.1, PARAG. UW-12
- DESIGNED PRESSURE : 150 psi (1 034KPa), 550 °F (280 °C) AND MORE ON REQUEST
- EXTERNAL FINISH : CLEANED WITH SOLVENT AND APPLICATION OF ONE COAT OF GREY PRIMER
- CONSTRUCTED IN ACCORDANCE WITH CSA B.51
- CARBON STEEL CONSTRUCTION

DIMENSIONS

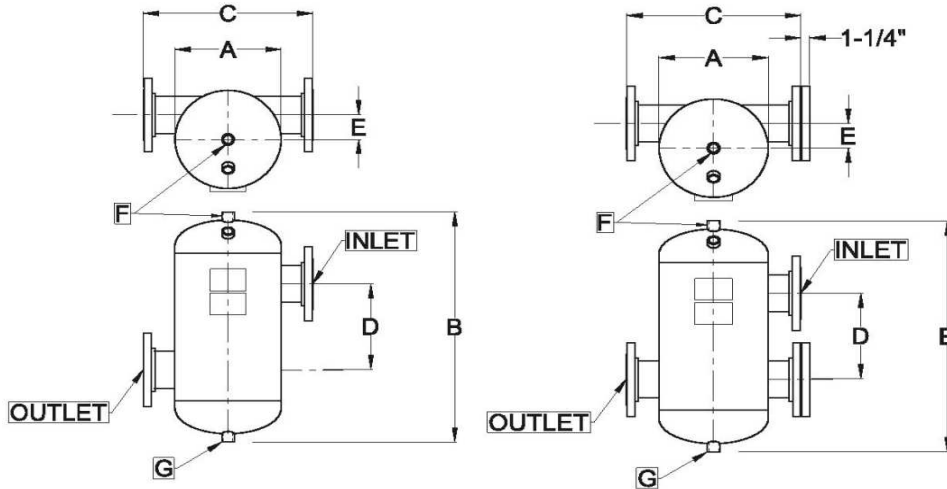

SAT

SATF

MODEL SAT = WITHOUT FILTER
MODEL SATF = WITH FILTER

MODEL SAT SATF	INLET		WEIGHT	
	in	mm	lbs	kg
025	2 1/2	64	79	36
030	3	76	134	61
040	4	102	124	57
050	5	127	170	77
060	6	152	229	104
080	8	203	400	182
100	10	254	765	348

QUANTITÉ : _____
 MODÈLE: SAT- _____
 MODÈLE: SATF- _____

MODEL	DIMENSIONS													
	A		B		C		D		E		F		G	
SAT	in	mm	in	mm	in	mm	in	mm	in	mm	in	mm	in	mm
SATF														
025	8 5/8	219	23	584	12 1/2	318	8	203	2 1/4	57	3/4	19	3/4	19
030	10 3/4	273	24	610	18	457	8	203	3	76	3/4	19	3/4	19
040	12	305	27	686	20	508	10	254	3	76	3/4	19	3/4	19
050	16	406	32	813	24	610	11	279	4 1/2	114	1 1/2	38	1 1/2	38
060	20	508	39	991	28	711	12	305	5 1/2	140	1 1/2	38	1 1/2	38
080	24	610	44	1118	32	813	16	406	6 1/2	165	1 1/2	38	1 1/2	38
100	30	762	55	1397	42	1067	20	508	8	203	2	51	2	51

PROJECT INFORMATION

REPRESENTATIVE: _____

JOB NAME: _____

TAGGING INFO: _____

ENGINEER: _____

CONTRACTOR: _____

ORDER No: _____

STANDARD CHARACTERISTIC

- CONSTRUCTED IN ACCORDANCE WITH THE ASME CODE, SEC VIII 2010 11a, DIV.1, PARAG. UW-12
- DESIGNED PRESSURE : 150 psi (1 034KPa), 550 °F (280 °C) AND MORE ON REQUEST
- EXTERNAL FINISH : CLEANED WITH SOLVENT AND APPLICATION OF ONE COAT OF GREY PRIMER
- CONSTRUCTED IN ACCORDANCE WITH CSA B.51
- CARBON STEEL CONSTRUCTION

DIMENSIONS

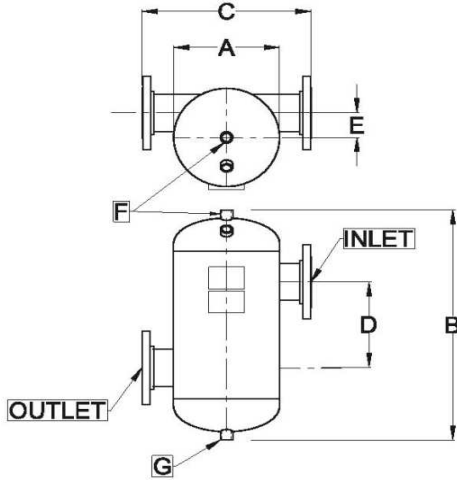

SAT

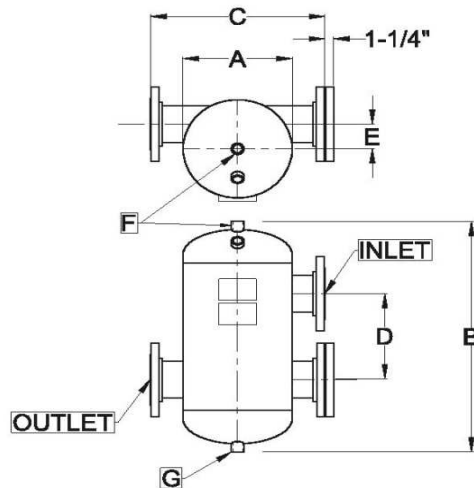

SATF

MODEL SAT SATF	INLET		WEIGHT	
	in	mm	lbs	kg
120	12	305	905	412
140	14	356	1435	653
160	16	406	2140	972
180	18	457	3015	1371
200	20	508	4520	2055
240	24	610	5875	2671

MODEL SAT = WITHOUT FILTER
MODEL SATF = WITH FILTER

QUANTITY : _____
 MODEL: SAT- _____
 MODEL: SATF- _____

MODEL	DIMENSIONS													
	A		B		C		D		E		F		G	
SATF	in	mm	in	mm	in	mm	in	mm	in	mm	in	mm	in	mm
120	36	915	65	1651	48	1220	24	610	9 1/2	241	2	51	2	51
140	42	1067	73	1854	54	1372	28	711	12	305	2	51	2	51
160	48	1220	82	2083	60	1524	32	813	14	356	2	51	2	51
180	54	1372	92	2337	66	1676	36	915	16	406	2	51	2	51
200	60	1524	101	2565	72	1829	40	1016	18	457	2	51	2	51
240	72	1829	120	3048	84	2134	48	1220	22	559	2	51	2	51

PROJECT INFORMATION

REPRESENTATIVE:

JOB NAME:

TAGGING INFO:

ENGINEER:

CONTRACTOR:

ORDER No: